

DIMENSIONS

612T TROMMEL

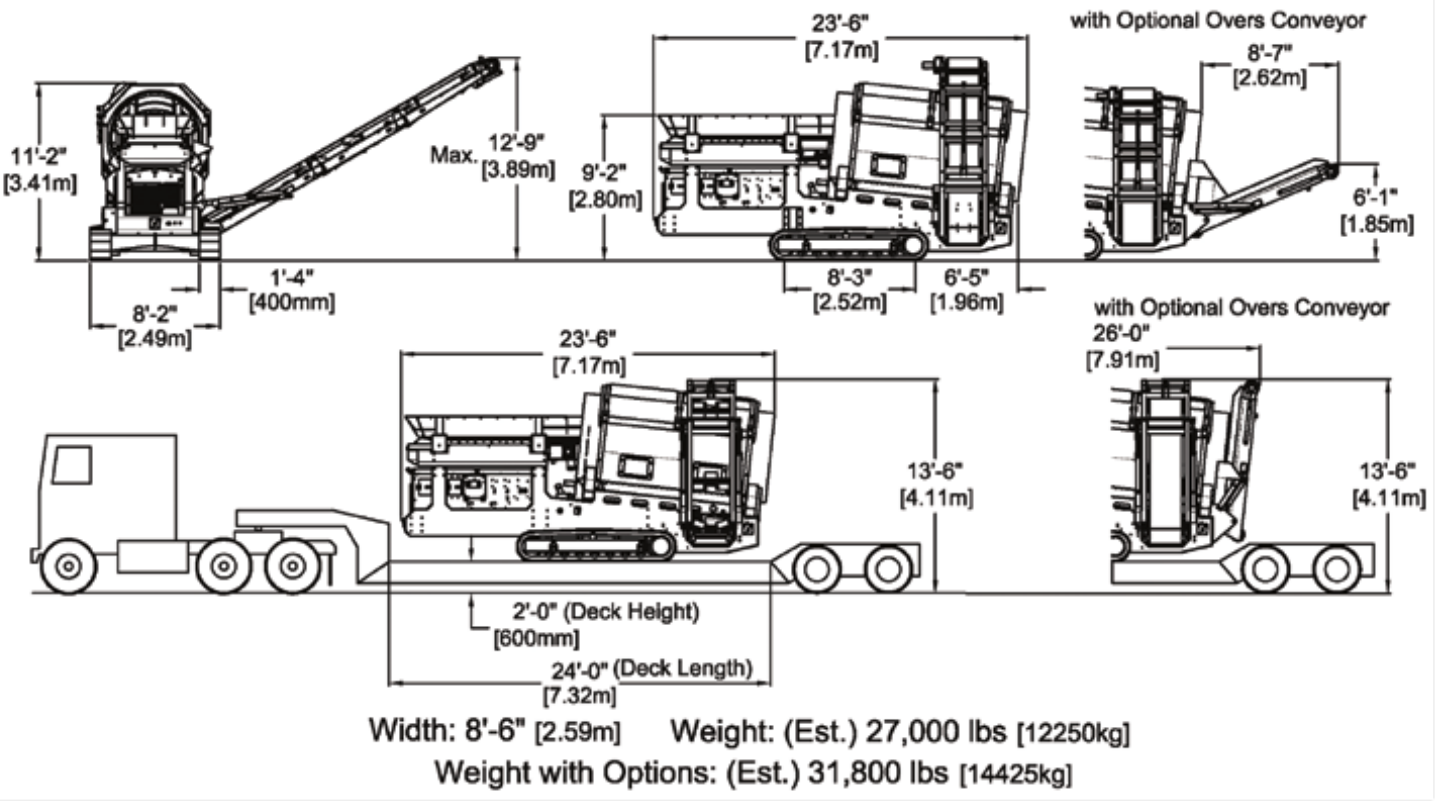

612W TROMMEL

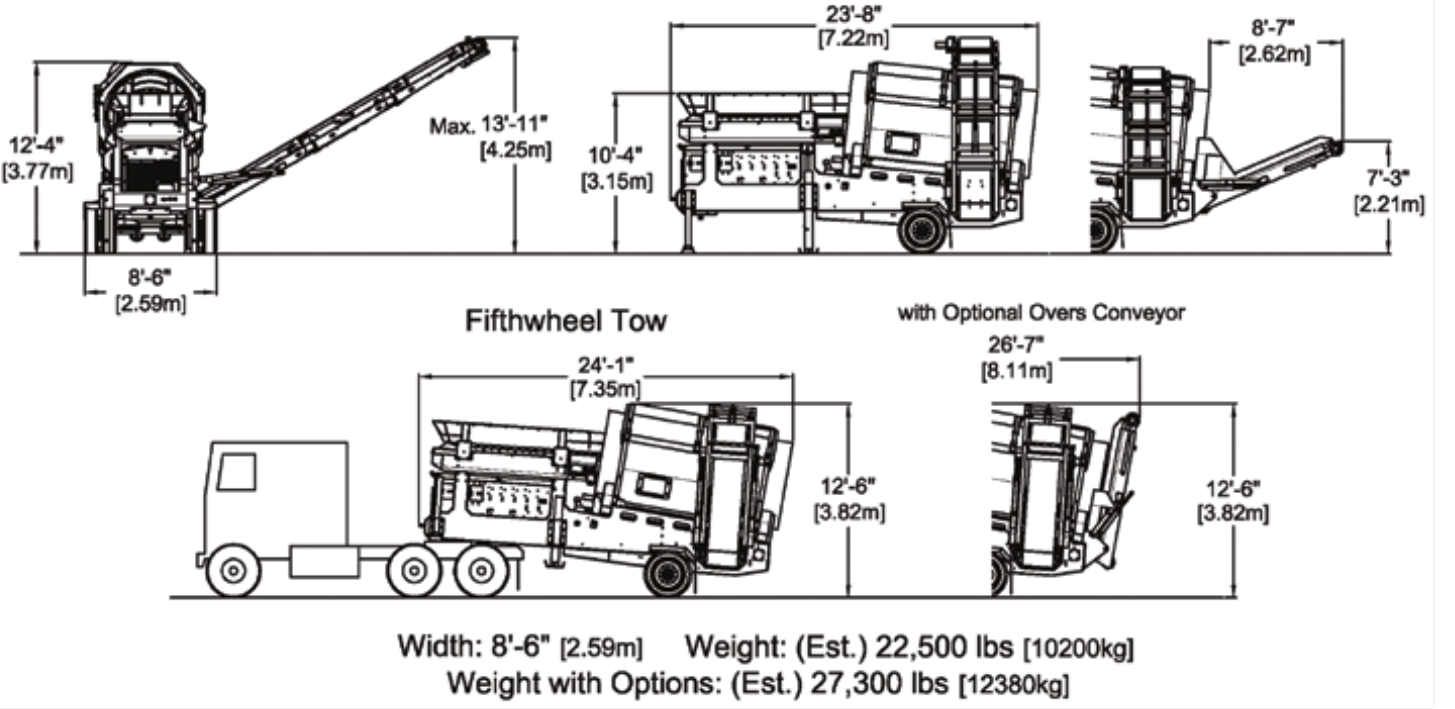

SCREEN MACHINE INDUSTRIES, INC.

AN AMERICAN MANUFACTURER OF PORTABLE CRUSHING AND SCREENING EQUIPMENT

Screen Machine Industries, Inc. is an innovative American manufacturer of portable machinery dedicated to material crushing, screening, washing and stockpiling. Our product offering provides production solutions across a vast array of applications ranging from 15 – 600 tons/yards per hour (rock, sand & gravel, concrete & asphalt, topsoil & compost products, just to name a few). Our engineering design philosophy of incorporating only industry leading brand name components and feature rich competitive advantages has prominently influenced our 40+ years of success.

The manufacturing process includes the utilization of high definition plasma tables, CNC fabrication equipment, robotic welders, advanced painting facilities and highly skilled mechanical technicians assembling these machines. Multiple levels of quality control and thorough run-time inspections are in place to ensure the quality and reliability that we demand and that you expect.

Screen Machine Industries, Inc. continues to make substantial investments in research and development. Our highly skilled engineers, combined with the latest computer technology, create the most innovative products in the screening industry. Numerous US Patents have been awarded as a result of our creative ambition in developing machinery superior to any in the world. We also strive to add the best design engineers to our organization. Several of our engineers are graduates of MIT and other prestigious universities throughout the United States. Our machines are designed to handle the most rugged demands our customers require.

Our diverse product line consists of heavy-duty track-mounted Jaw and Impact Crushers, Spydres, Scalper, Trommel and Conventional Screening and Shredding Plants. Portable Radial Stacking Conveyors complete the product line with sizes available to fit most every job.



Screen Machine Industries, Inc. Corporate Headquarters



SCREEN MACHINE INDUSTRIES, INC

10685 Columbus Parkway
Pataskala, Ohio 43062 USA
1-740-927-3464 800-837-3344 (USA Only)
email@screenmachine.com
www.screenmachine.com

DISTRIBUTED BY:

AN AMERICAN MANUFACTURER OF PORTABLE CRUSHING AND SCREENING PLANTS

612T & 612W TROMMELS



10685 COLUMBUS PARKWAY, PATASKALA, OHIO 43062
1-740-927-3464 800-837-3344 (USA ONLY) WWW.SCREENMACHINE.COM

KEY FEATURES

TROMMEL SCREEN

- **6' x 12' trommel drum screen**
160 square feet (14.89 sq. m) of actual wire cloth screening surface area
- **Four wheel drive with twin motors**
Twin drive shafts generate powerful traction and prevent wheel slippage when screening heavy, wet materials
- **Heavy duty trommel drum with massive triangular tumbling paddles**
- **Unique screen cloth cable/hinge lock design**
Facilitates extremely quick and easy screen change or replacement
- **Self-cleaning brushes**
Two self-cleaning adjustable tensioned nylon brushes ensure a clean screen surface for continuous operation
- **Variable RPM drum speed**
Drum speed can be hydraulically adjusted from 0 to 32 RPM for efficient separation of any type and size of material
- **Multiple screen choices and sizes available**
Square Wire Cloth
Slotted Wire Cloth
Punch Plate



POWER SYSTEM & CONTROLS

- **84 HP Yanmar® Tier III diesel engine w/ electronic throttle**
Liquid cooled and turbo-charged with enough horsepower to handle your heaviest materials
- **Large 70 gallon fuel tank**
Over 16 hours of continuous material processing without the need to refuel
- **Wireless remote control movement and operation** (612T only)
Complete handheld control of machine with a range of 100 yards (91.4 mm)
- **Three emergency stops mounted to the machine** (612T Only)
An additional shut-off button is located on the wireless remote transmitter
- **Independent hydraulics**
Separate valve, pump and motor for the Feeder, Screen, Conveyor and Cylinders
- **Baffled 70 gallon hydraulic tank and cooler**
A cool hydraulic system maintains a constant level of performance and long life
- **Unique large engine compartment design allows quick access for engine maintenance**
- **Easy to operate control panel with lockable access doors**



Specifications Subject to Change Without Notification

STRUCTURE

- **USA sourced grade 80 steel unibody mainframe**
Massive unibody frame made from high strength wear-resistant steel handles the stresses of rough terrain movement and ensures long life integrity in the most demanding job applications
- **Manufactured with robotic welders generating precision fabrication for long-term durability**
- **Modern painting facilities apply three coats of specially designed paints**
Special paints protect the steel and create a first class finish to enhance your investment
- **American made in Columbus, Ohio with American steel and labor**



FEEDER

- **Large 4.5 cubic yard (3.44 cu.m) open ended hopper**
Expandable to 7.5 cubic yards (5.73 cu. m) w/ optional hopper extension
- **Designed to be fed with a 1 - 3 cubic yard (.76 - 2.29 cu.m) front end loader**
Hopper can be loaded from either side
- **Low hopper feed height accommodates most loaders without a ramp**
9'-2" (2.8 m) Feed Height on 612T Tracked Version
10'-4" (3.15 m) Feed Height on 612W Wheeled Version
- **Hydraulically variable speed feeder belt**
Adjustment of the feeder speed controls the amount of material entering the trommel
- **36" wide (.91 m) heavy duty 330 piw main feeder belt**
- **5" (12.7 cm) rubber wrap idler**
This idler wraps the feeder belt around the head pulley to prevent pulley slippage
- **Precision® lagged-head and wing type tail pulleys**



CONVEYORS

- **Side discharge conveyor high enough for direct truck loading**
13'-11" (4.25 m) discharge height on side stacking conveyor (612W)
12'-9" (3.89 m) discharge height on side stacking conveyor (612T)
Variable conveyor angle ranging from 18° to 30°
- **Capable of true wireless "on the fly" windrow stockpiling** (612T)
You never have to handle screened materials twice
- **Fines unders belt is 42" wide (106.68 cm) 150 PIW**
- **Side discharge belt is 24" wide (60.96 cm) 220 PIW**
- **Guide rollers on all conveyor belts for centered belt tracking**
- **Spring loaded belt scraper bars made of UHMW plastic**
- **Precision® herringbone lagged head pulleys**
- **Precision® wing type tail pulleys**
- **Goodman® 5" (12.7 cm) troughing idlers**
- **Rubber disc return idlers**



PORTABILITY

- **Heavy duty tracked undercarriage** (612T)
Wireless remote controlled movement by Remtron®
- **Large tracked footprint ensures stability on soft ground**
8'-3" (2.52 m) ground length with 16" (400 mm) wide shoes (612T)
- **Track movement speed is .71 miles (1.14 km) per hour** (612T)
- **22,500 lb. axle w/ air brakes** (612W)
Four 8.25-22.5 tires are standard
- **Fifth wheel pin transport** (612W)
Brake lights, turn signals and mud flaps are all standard features
- **Hydraulic landing gear** (612W)
Allows for easy tractor connection without additional equipment
- **Hydraulic fold-over conveyor for easy portability**



OPTIONS

- **Oversize material conveyor with 36" (.91 m) wide 220 PIW belt**
612W Stockpile Height 7'-3" (2.21 m)
612T Stockpile Height 6'-1" (1.85 m)
- **Tethered pendant movement** (612T)
A cord attached pendant can be added in addition to the standard wireless remote for added security
- **Hydraulic tipping grizzly w/ 5" (12.7 cm) space openings**
Triggered by wireless remote control
- **Hopper extension available for additional capacity**
- **Vibratory grid**
A complete vibratory screen mounted on top of the hopper for pre-screening

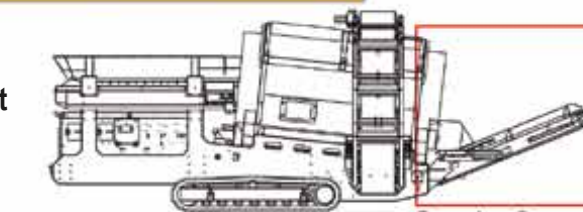

Oversize Conveyor



Hydraulic Tipping Grizzly



Vibratory Grid

Screen choices include grizzly, punch plate or woven wire cloths
Two-tiered finger deck option is available for materials with heavy vegetation

PRODUCT SUPPORT

- **Factory headquarters located near Columbus, Ohio**
- **Lifetime toll free engineering telephone support** (USA Only)
- **Responsive warranty support**
- **Rapid response parts availability**
- **Detailed operational, service & parts manuals**
- **Extensive distributor network**